



LED Mounting Process Techniques for the Nichia 131 or 170 Series LEDs

Light Emitting Diode

Table of contents

1. Overview	2
2. Applicable Part Numbers	2
3. Mounting Process Preparation	2
4. Solder Printing	5
5. LED Mounting	9
6. Reflow	16
7. Mounting Test	19
8. Inspection	20
9. Precautions for Assembled PCBs.....	21
10. Summary	22

The Nichia part numbers NCSx131x, NC2x131x, NCSx170x, NC2x170x, and NJSx170x within this document are merely Nichia's part numbers for those Nichia products and are not related nor bear resemblance to any other company's product that might bear a trademark.

1. Overview





Nichia’s surface-mount LEDs are designed to be mounted using a pick-and-place machine. However, depending on the operation conditions set for the machine or how the LEDs are handled during the mounting process, failures of the LEDs (i.e. damage to the LED, reliability issues, etc.) or mounting errors may occur.

This application note provides considerations/precautions for the mounting process of the Nichia 131 or 170 Series LEDs.

2. Applicable Part Numbers

This application note applies to the LEDs shown in Table 1.

Table 1. Applicable LED Part/Series Numbers

Category	Nichia 131 Series ¹		Nichia 170 Series ¹		
Part Number ²	NCSx131x	NC2x131x	NCSx170x	NC2x170x	NJSx170x
Example of Package Appearance	 NCSW131G	 NC2W131F	 NCSW170G	 NC2W170G	 NJSW170F
Package Size (Unit: mm)	1.8×1.45×0.75	3.0×1.6×0.75	1.8×1.45×0.75	3.0×1.6×0.75	1.6×1.2×0.75

3. Mounting Process Preparation



3.1 Reel and Embossed Carrier Tape Specifications

The LEDs are delivered in an embossed carrier tape and a reel as shown in Figure 1. The detailed specifications of the embossed carrier tape are available in the applicable specification for each LED part number.

Note:

- ¹ The electrode pattern on the back of the package for the Nichia 131 Series and Nichia 170 Series is different.
- ² The x represents a letter that follows the alphanumeric code of the same LED type.
(Ex: NCSx170x → NCSW170D, NCSW170F, NCSY170F, NCSA170G, NCSW170G, NCSW170G-SA, etc.)

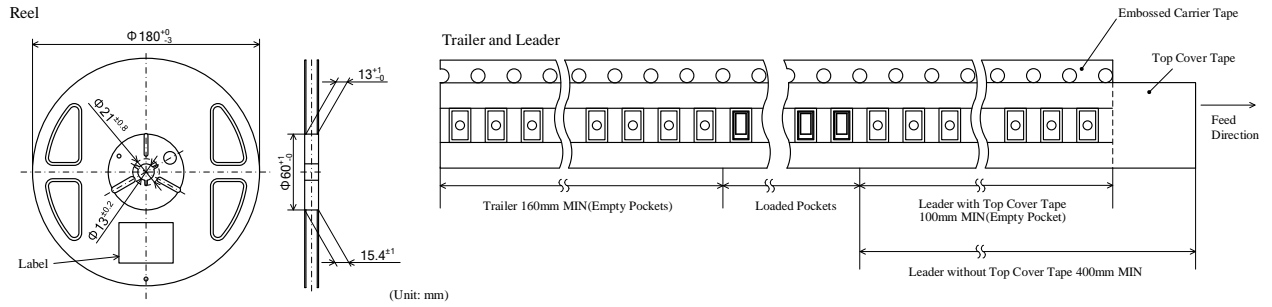

Figure 1. Reel and Embossed Carrier Tape (Example for the NC2x170x LED)

3.2 Prevention of Moisture Absorption

The reel of the LEDs is sealed in a moisture-proof aluminum bag as shown in Figure 2. If the package absorbs moisture and is exposed to heat during soldering, it may cause the moisture to vaporize and the package to expand and the resulting pressure may cause internal delamination (see Figure 3). This may cause the optical characteristics to degrade. To minimize moisture absorption in storage/transit, moisture-proof aluminum bags are used for the LEDs with a silica gel packet to absorb any air moisture in the bag.

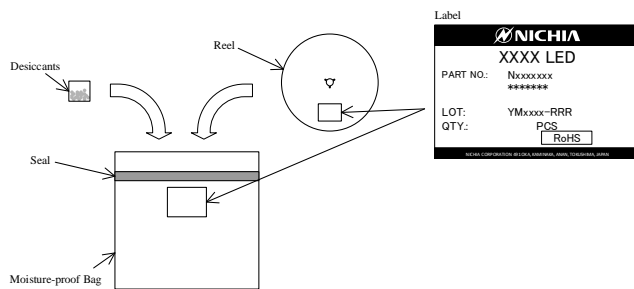

Figure 2. Moisture-Proof Aluminum Bag

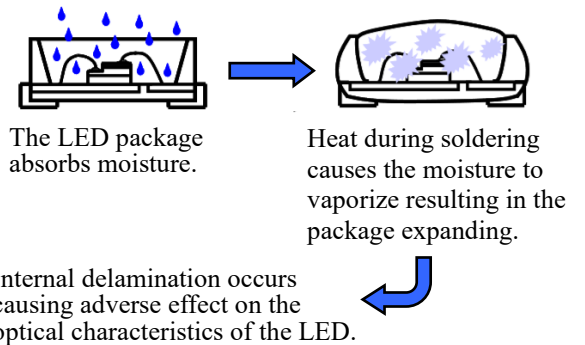

Figure 3. Schematic Diagram of LED's Moisture Absorption and Vapor Expansion of the Moisture

3.3 Storage of the LEDs

Table 2 provides the required storage conditions before and after opening the moisture-proof aluminum bag.

Table 2. Storage Conditions

Conditions	Temperature	Humidity	Storage Time	
Before Opening the Moisture-proof Aluminum Bag	≤30°C	≤90%RH	Within 1 Year from Delivery Date	
After Opening the Moisture-proof Aluminum Bag	≤30°C	≤70%RH	MSL2	Within 1 Year
			MSL3	Within 168 Hours

This document contains tentative information, Nichia may change the contents without notice.

The “After Opening” storage time is different depending on the Moisture Sensitivity Level (MSL)³ of the LED. Refer to the specification for each LED part number for the MSL to ensure that soldering is completed within the specified storage time.

To store any remaining unused LEDs, use a hermetically sealed container with silica gel desiccants. Nichia recommends placing them back to the original moisture-proof aluminum bag and reseal it.

If the storage time has been exceeded for the LEDs whose “After Opening” storage time is 168 hours, ensure that the LEDs are baked for ≥ 24 hours at a temperature of $65 \pm 5^\circ\text{C}$ before use. If any pink silica gel beads are found within the storage times (see Figure 4), ensure that the LEDs are baked in the same manner. Baking should only be done once.



A. When packed for shipment

B. After being left for 168 hours at 30°C and 70%RH

The blue silica gel beads absorbed moisture and turned pink.

Figure 4. Appearance of Silica Gel Desiccants

When baking the LEDs, remove the reel of the LEDs from the storage container (e.g. a moisture-proof aluminum bag). See Figure 5.



Figure 5. Example for Baking the LEDs

If the LEDs are stored in a high temperature environment ($\geq 70^\circ\text{C}$) for a long period of time, the resin portion of the LED may stick to the top cover tape, causing pick-up errors; storing the LEDs in this manner may also cause deformation of the embossed carrier tape.

Note:

³ Refer to IPC/JEDEC STD-020 for detailed information regarding the MSL.

Do not store the LEDs in a manner where excessive external force may be applied to the reel (e.g. the reel is stored using a vacuum seal, heavy objects are stacked onto the reel, etc.) since it may cause the embossed carrier tape to deform; see Figure 6. If the embossed carrier tape deforms, the LEDs inside the pockets of the embossed carrier tape may tilt, causing damage to the LEDs and/or pick-up errors.

Correct



Before Opening the Bag with a Reel in it

Incorrect



Squashed Reel as a Result of Excessive Vacuum Sealing

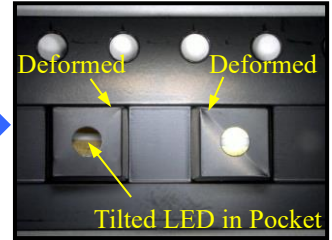

Figure 6. Correct/Incorrect Examples for Embossed Carrier Tape after Vacuum Sealing

4. Solder Printing



If the LED is not mounted onto a PCB with an appropriate amount and shape of solder paste, the expected characteristics of the LED may not be obtained. In order to maintain the amount/shape of solder paste in the printing process, the soldering pad pattern and metal solder stencil aperture pattern should be optimized as well as the printing conditions, and the solder paste must be prepared properly prior to use.

4.1 Preparations for Solder Paste

Usually, the solder paste that is stored in a refrigerator cannot be used immediately and needs to be stirred before use. The purpose of the stir is to restore the even distribution of solder particles and flux that became uneven due to storage in the refrigerator. If the solder paste is not mixed evenly, it interferes with the rolling performance, leading to an inappropriate amount/shape of the solder when printed on the PCB.

The solder paste container should not be opened immediately after taken out from the refrigerator. Otherwise the solder paste absorbs moisture due to condensation.

Leave the solder paste at room temperature for approximately 60 minutes after taking it out from the refrigerator to ensure that it returns to room temperature before stirring. The temperature of the solder paste will increase if it is stirred for a long time, which deteriorates the flux. Stirring for one minute may be enough for some kinds of solder paste; determine the stirring duration based on the solder paste manufacturer's recommendation. If it is suspected that the temperature of the solder paste increased in the container after stirring, the stirring duration may have been too long; shorten the stirring duration.

4.2 Soldering Pad Pattern and Metal Solder Stencil Aperture Pattern

The figures below show the recommended soldering pad pattern and metal solder stencil aperture pattern for the NCSx170x LEDs as examples of the patterns used to mount an LED onto a PCB. For other LED part number patterns, refer to the applicable specification for each LED part number.

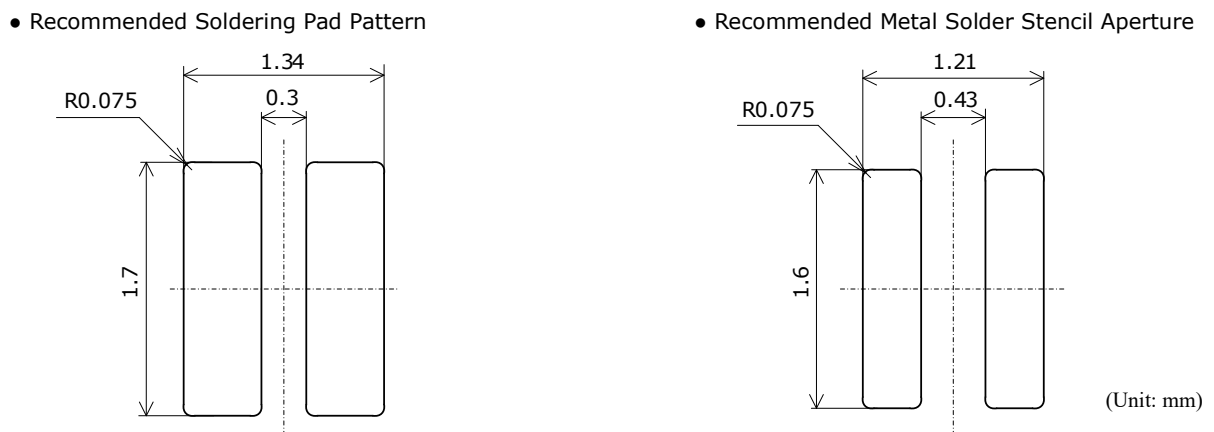

Figure 7. Soldering Pad Pattern and Metal Solder Stencil Aperture Pattern Recommended for the NCSx170x

4.3 Printing Condition Adjustment

Adjust the squeegee conditions and the metal solder stencil separation conditions to print with the correct amount and shape. The speed, pressing pressure, and angle of the squeegee affect the amount and condition of the solder paste filling the metal solder stencil aperture. Additionally, the speed of the separation and the distance affects how the shape of the solder on the PCB stays consistent with each use. These are also affected by the thickness of the metal solder stencil, the aperture pattern, and the surface roughness of the aperture wall.

In order to prevent the occurrence of solder bridges, etc. and maintain optimal printing conditions, adjust the cleaning method, conditions, and frequency of the metal solder stencil.

Adjust the printing conditions to obtain an appropriate solder shape (see Figures 8 and 9 for examples). An appearance inspection after solder printing is recommended in order to check if the solder paste has been printed appropriately.

If the solder printing process is carried out continuously for a long period of time, the viscosity of the solder paste may increase, leading to printing failures due to clogging of the metal solder stencil aperture and poor release of the solder paste. To maintain an appropriate solder shape during continuous operation, it is important to check the solder stencil apertures for clogging and check the viscosity of the solder paste whenever appropriate.

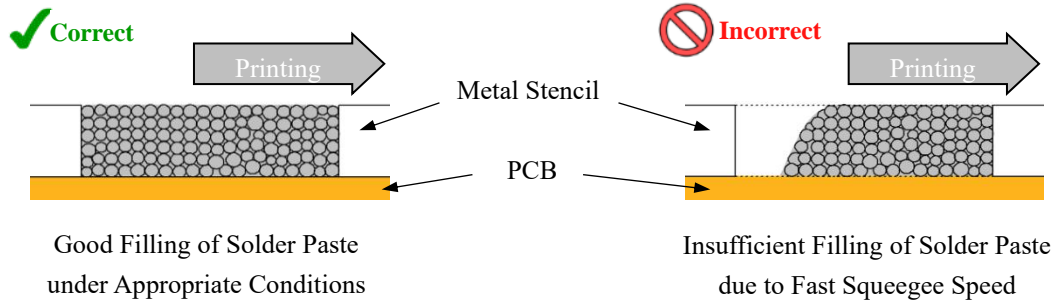

Figure 8. Squeegee Speed and Solder Paste Filling in the Metal Solder Stencil Aperture

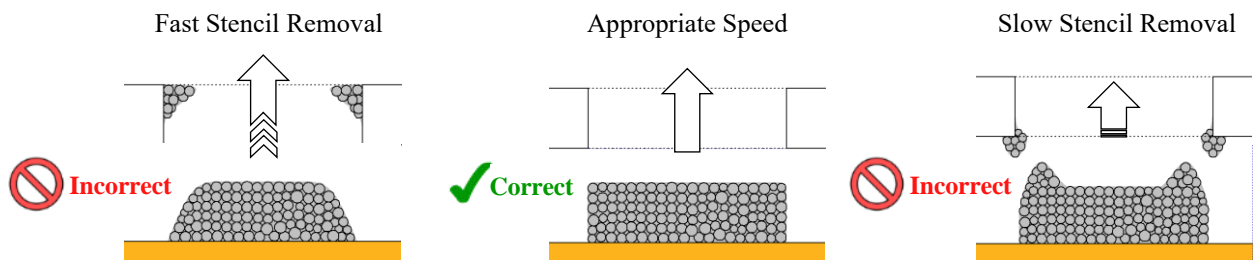

Figure 9. Speed of Solder Stencil Removal and Shape of the Solder Paste

4.4 LED Failures Related to Poor Solder Printing

If a metal solder stencil aperture is clogged and/or the conditions of the board separation is not appropriate, a sufficient amount of the solder paste may not be applied to the PCB. This will lead to insufficient heat dissipation of the LED causing the junction temperature (T_J) of the LED to significantly increase, resulting in a reduction in the luminous flux and/or an adverse effect on the reliability performance. In the worst case, this may cause the circuit to become open causing the LED not to illuminate due to an electrical connection failure between the LED and the PCB or the LED to be removed from the PCB. Figure 8 shows examples of the solder printing failures.



⇒ Reduction in Luminous Flux
 Caused by a significant increase in the T_J due to insufficient heat dissipation.

a) Solder Printing Failure Resulting in a Reduction in the Luminous Flux of the LED



⇒ Open Circuit/LED Removal from the PCB
 In some cases, the circuit may become open or the LED could be removed from the PCB.

b) Solder Printing Failure Resulting in Open Circuit/LED Removal from the PCB

Figure 10. Examples of the Failures Caused by Insufficient Solder Amount

Nichia performed a verification test of how heat dissipation would affect the LEDs if the amount of solder paste is insufficient. Figure 12 shows that the smaller the amount of the solder paste is, the higher the thermal resistance ($R_{\theta JA}$) and T_J will be.

- Evaluated LED: Similar LEDs to the NC2W170D LED
- Test Method: Nichia evaluated the $R_{\theta JA}$ and T_J values with different solder volumes by covering certain areas of the soldering pads with tape to apply the solder paste only to a specified area (i.e. 25 to 100% of the whole area of the soldering pad). See Figure 11.
- PCB Used: Aluminum-core PCB with a thickness of 1.5mm, Copper layer thickness: 105 μ m
- Input Power: 6W

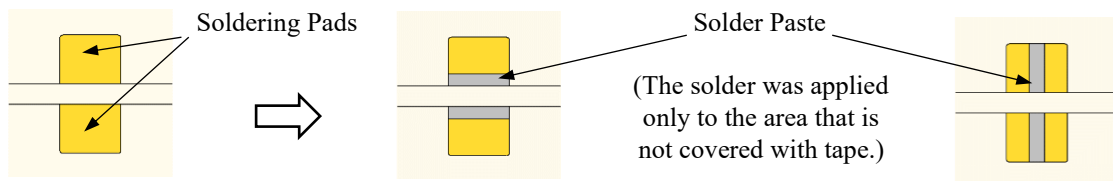

a) Soldering Pad Pattern b) 25% Solder Applied to the Soldering Pads in Vertical Direction c) 25% Solder Applied to the Soldering Pads in Horizontal Direction

Figure 11. How the Solder Paste was Applied to the Soldering Pads for the Evaluation

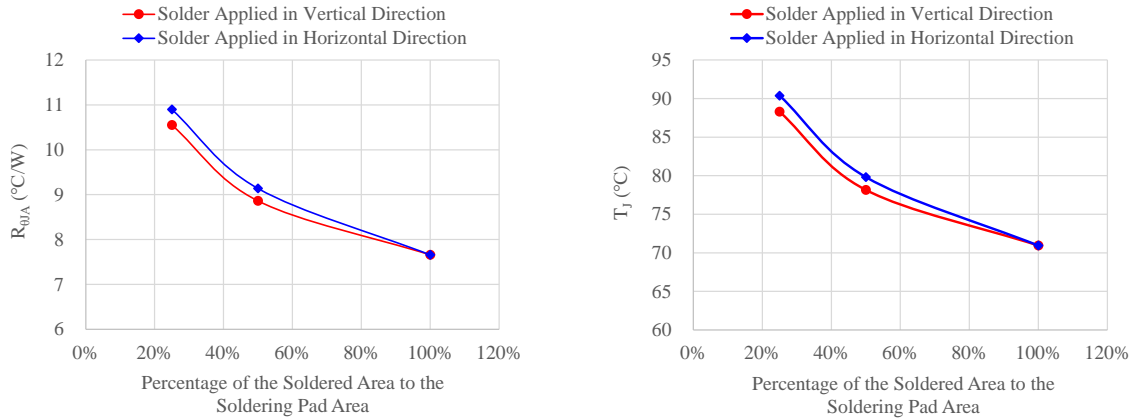

Figure 12. The R_{θJA} and T_j Values Measured with Different Amounts of Solder Paste

In order to ensure that the appropriate amount of solder paste is applied to the soldering pads consistently, verify the amount of the solder paste by conducting an appearance inspection after the solder printing and/or an X-ray examination after the LED is mounted.

5. LED Mounting



If the parameter settings for the pick-and-place machine and the mounting conditions are inappropriate, it may cause issues such as the LEDs falling out of the embossed carrier tape pocket or sticking to the top cover tape, pick-up errors, poor precision of the placement position, and/or damage to the LEDs. This section provides the precautions for the LED mounting process that uses a pick-and-place machine and what measures to be taken when an LED pick-up/placement error occurs.

5.1 Recommended Nozzle

If excessive force is applied to the emitting surface of the LED, it may be damaged, which may affect the performance/reliability of the LED. Nichia recommends using a nozzle specifically designed for the LEDs (see Figure 13). Additionally, if the tip of the nozzle has burrs, chipping, or foreign substances, the emitting surface may be damaged or contaminated. Ensure that the tip of the nozzle is cleaned before starting the pick-and-place operations.

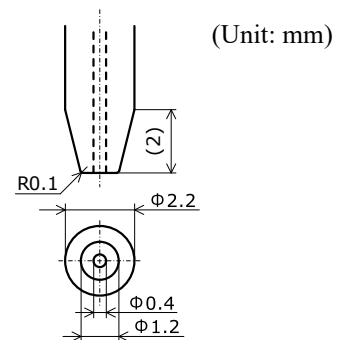

Vacuum pressure: $\leq 8\text{N/cm}^2$ ($\leq 0.8\text{kgf/cm}^2$)

Placement pressure: $\leq 3.5\text{N/mm}^2$ max. force: 5N

Figure 13. Recommended Nozzle

5.2 Pick-up Position

When setting the LED pick-up position, ensure that the center of the nozzle and the center of the emitting area of the LED are aligned (see Figure 14). If the nozzle picks up the LED at an edge of the emitting area, this may damage the emitting surface (i.e. chip, crack, etc.).

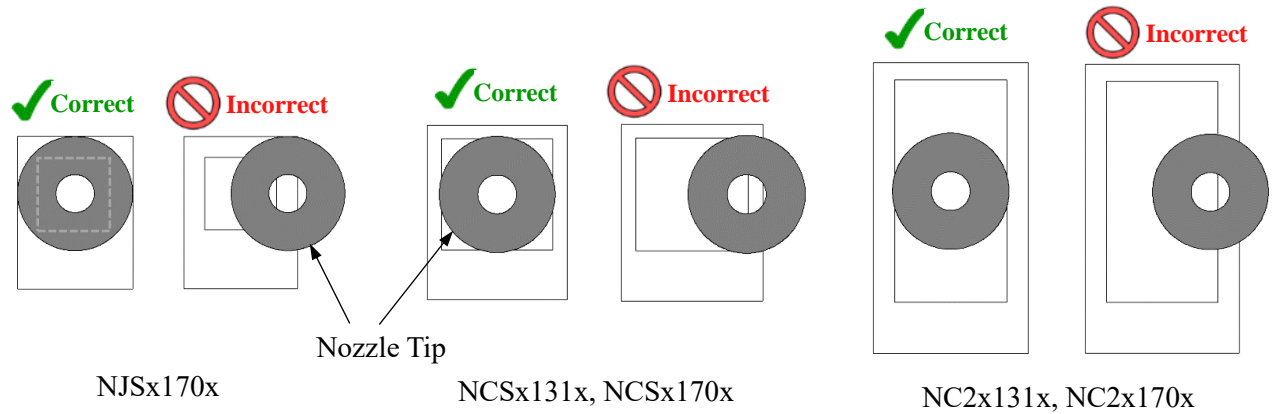

Figure 14. Nozzle Position for LED Pick-up

5.3 Nozzle Height for LED Pick-up

The recommended nozzle height for pick-up operations is where the tip of the nozzle touches the top surface of the LED. Refer to the outline dimensions of the embossed carrier tape and the LED detailed in the applicable specification for each LED part number to determine the nozzle height. For the LEDs in the scope of this application note, the recommended nozzle height is 0.2mm below the edge of the embossed carrier tape pocket (see Figure 15).

This recommended nozzle height for pick-up operations has been determined by Nichia using Nichia's equipment and verification conditions and may not function as expected with some other pick-and-place machines. If the pick-up operations are unstable even with using the recommended nozzle height, adjust the nozzle height appropriate for the pick-and-place machine being used.

If the pick point of the nozzle is too high, it may cause insufficient suction power leading to picking errors (e.g. the nozzle's failure to pick/lift the LED into the air, incorrect picking causing the LED to tilt when in the air) due to a large gap between the LED and the nozzle. If the pick point of the nozzle is too low, it may cause issues (e.g. causing the embossed carrier tape to shake, causing the tape pocket to deform) leading to picking failure.

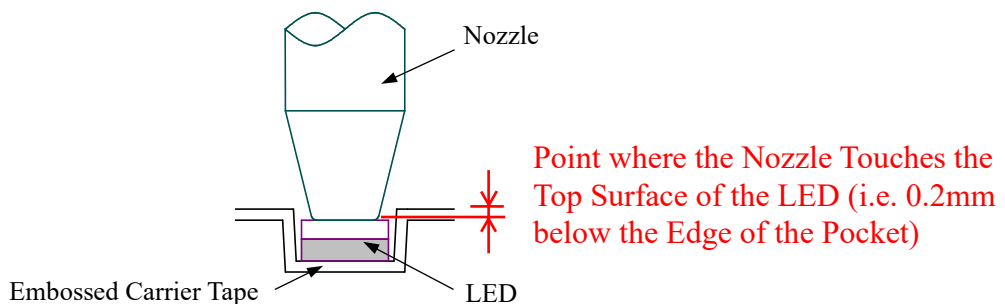

Figure 15. Recommended Nozzle Height for Pick-up Operation

This document contains tentative information, Nichia may change the contents without notice.

5.4 Types of Tape Feeder

There are two types of tape feeders: mechanical (pneumatic) feeders and electrical (motorized) feeders. A mechanical feeder takes a pause from feeding between the LED pick-ups. This may cause vibration resulting in the LED tilting or flipping over within the embossed carrier tape pocket. An electrical feeder keeps feeding the tape at a constant speed without a pause; this enables stable pick-up operations to be performed. Nichia recommends using a motorized tape feeder (see Figure 16). The vibration can be reduced by slowing down the feed speed of the tape feeder. Optimize the feed speed if suction failure occurs.



Left: Electrical
Right: Mechanical

Figure 16. Tape Feeders

5.5 Top Cover Tape Removal Position and LED Pick-up Position

If the top cover tape is removed early before LED pick-up, the LED may move within the embossed carrier tape pocket and hit the feeder cover resulting in the emitting surface being damaged. Nichia recommends removing the top cover tape immediately before LED pick-up (see Figure 17).

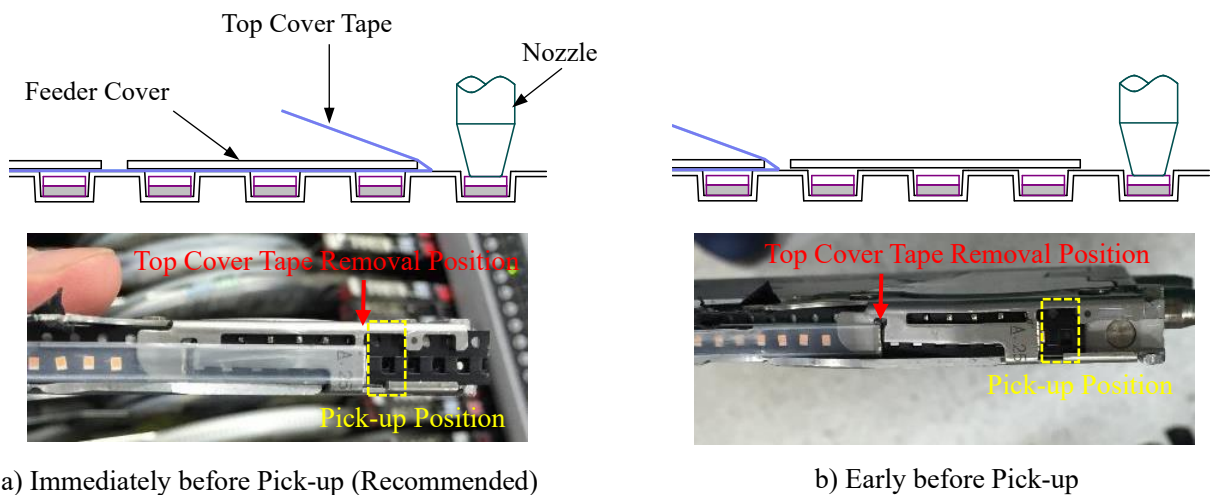

a) Immediately before Pick-up (Recommended)

b) Early before Pick-up

Figure 17. Top cover Tape Removal Positions

5.6 Measures against Static Charges

If the pick-and-place operations are performed in environments where static charges are likely to occur (e.g. low humidity environment), the LEDs may stick to the top cover tape when the top cover tape is removed due to static charges, leading to pick-up errors. If a large amount of static charge is generated, the LEDs may stick to the top cover tape successively as shown in Figure 18. The following examples are recommended measures to reduce the static charge:



Figure 18. LED Sticking due to Static Charge

a) Humidity Control

Controlling humidity in the operation environment is a very effective measure against static charges. When the humidity in the environment is greater than 50%RH, it can largely reduce static charges that occur when removing the top cover tape (see Figure 19).

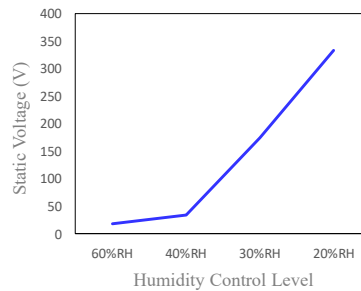

Figure 19. Humidity vs. Static Voltage

b) Feed Speed of the Tape Feeder

If the movement of the LEDs within the embossed carrier tape pocket is reduced by slowing down the feed speed of the tape feeder, the static charge may be reduced (see Figure 20).

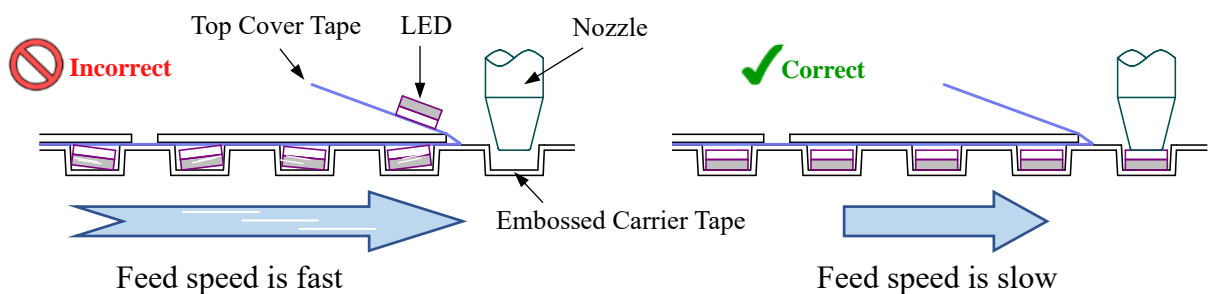

Figure 20. Feed Speed of the Tape Feeder

c) Magnet under the Embossed Carrier Tape

If a magnet is placed under the embossed carrier tape, it may prevent the LED from sticking to the top cover tape due to the attraction generated between the magnet and the electrodes of the LED. Use a magnet recommended for the pick-and-place machine being used (see Figure 21).

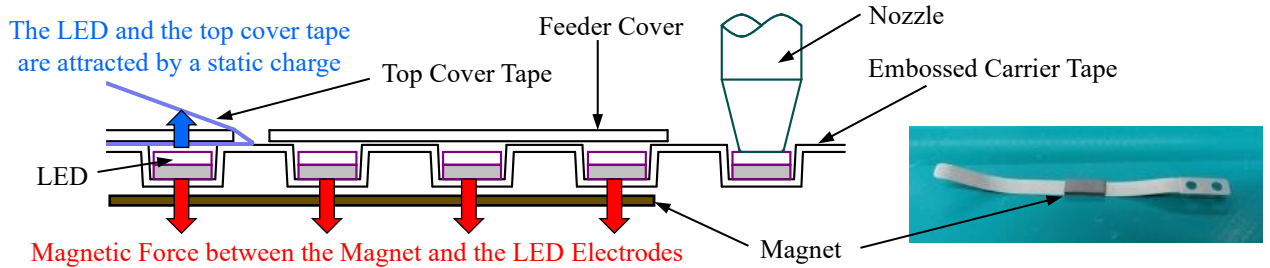

Figure 21. Magnet under the Embossed Carrier Tape

d) Changing the Top Cover Tape Removal Position

If the top cover tape removal position is changed to early before where the LED is picked up, it may prevent the LEDs from sticking to the top cover tape. However, this may lead to the LED hitting the feeder cover; necessary measures (e.g. using a magnet, adjusting the feed speed) should be taken to reduce the movement of the LED within the embossed carrier tape pocket.

5.7 LED Placement

When placing the LED on the PCB, the nozzle should further press the LED 0.2mm onto the PCB from the height where the LED first touches the solder paste (see Figure 22). If the placement depth of the nozzle is insufficient, the LED may float or shift after reflow. If the placement depth is too large, an excessive pressure may be applied to the LED resulting in the emitting surface being damaged and/or solder balls may occur.

The relationship between the placement depth and the placement speed determines the size of the nozzle's placement pressure on the LED. A large placement pressure may damage the emitting surface and/or the package affecting the performance and/or the reliability of the LED. Ensure that the placement pressure is $\leq 3.5\text{N/mm}^2$ and the maximum force applied to the LED does not exceed 5N. The placement pressure changes if there is a warpage in the PCB; verify that the operation conditions do not cause damage to the LED in the actual mounting process before starting the operation.

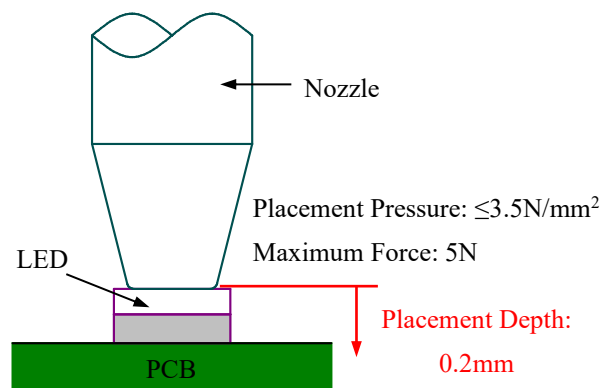

Figure 22. Recommended Nozzle Height for Placement Operation

Examples of the Causes of the Placement Errors

a) Solder Printing Failures

If a solder printing failure (e.g. significantly small amount of the solder paste printed on the PCB) occurs or if the LED is placed on the PCB after the solder paste is printed on it and left for a while, adhesion of the solder paste may become insufficient causing placement errors (e.g. the LED to stick to the nozzle after placement).

b) Foreign Substance on the Nozzle Tip

If a foreign substance is attached to the tip of the nozzle, the LED may stick to the nozzle and not be released after placement. Ensure that the tip of the nozzle is not contaminated and/or has no foreign substance before pick-and-place operations.

5.8 Rewinding of a Tape on a Reel

To rewind the embossed carrier tape when the operation is interrupted, the force applied must be $\leq 10\text{N}$ to the embossed carrier tape. Otherwise, the LED may stick to the top cover tape and/or the embossed carrier tape pocket may be deformed resulting in the LED being damaged.

5.9 Check List for Pick-up/Placement Errors

Since the LEDs in the scope of this application note are small and lightweight, there is a possibility that pick-up/placement errors may occur. Table 3 provides a check list to prevent the pick-up/placement errors. Use the list as reference to prevent these errors.

Table 3. Check List to Prevent LED Pick-up/Placement Errors

Check Item		Answer		Note
Pick-up	Is the feeder being used is an electrical (motorized) feeder?	Yes	No	Mechanical feeders may cause frequent vibration; the LED may move in the tape pocket causing pick-up errors more likely to occur.
	Is the top cover tape removed immediately before the LED pick-up position?	Yes	No	If the top cover tape is removed early before LED pick-up and that causes the emitting surface of the LED to be damaged, change the top cover tape removal position to immediately before pick-up. If removing the tape early before pick-up is preferred in order to prevent static charges, measures should be taken to reduce the vibration as much as possible (e.g. slowing down the feed speed).
	Is a magnet placed under the tape feeder?	Yes	No	Pick-up errors caused by static charges/vibration may be reduced by using a magnet.
Placement	Is the nozzle being used specifically designed for the LED according to the size recommendations?	Yes	No	If pick-up/placement errors occur or the emitting surface of the LED is damaged, use a nozzle specifically designed for the LED.
	Are there any contamination/foreign substances on the tip of the nozzle?	Yes	No	Contamination/foreign substances may cause the LED to stick to the tip of the nozzle resulting in placement errors.
	Are there any burrs, chipping, or scratches on the tip of the nozzle?	Yes	No	Burrs/chipping/scratches on the nozzle tip may damage the emitting surface of the LED.
	Has an LED placement with a slower placement speed been tested?	Yes	No	If the placement speed is fast, the LED may not be released from the nozzle (the nozzle may fail to mount the LED).
	Is the placement pressure $\leq 3.5\text{N/mm}^2$ and the maximum stress $\leq 5\text{N}$?	Yes	No	If the placement speed is fast, the force (pressure) applied to the LED increases, which may cause the emitting surface of the LED to be damaged.
	Is the pressing depth set 0.2mm?	Yes	No	If the pressing depth is too large, the force increases, which may cause the emitting surface of the LED to be damaged.
Environment	Is the storage temperature appropriate (not too high)?	Yes	No	If the LEDs are stored under a high temperature for a long time, they may stick to the top cover tape.
	Is the humidity controlled in the storage/operation environments to reduce static charges?	Yes	No	Controlling the humidity can reduce the occurrence of surge from static electricity and of static charges.
Others	Is the PCB flat (i.e. not bent/warped)?	Yes	No	If the PCB is severely warped or bent, the LED may not touch the solder paste on the PCB properly, causing placement errors.
	Do the sizes of the metal solder stencil apertures conform to the recommendations?	Yes	No	If the solder amount is excessively small, it may cause placement errors.
	Is the amount of solder being printed stable?	Yes	No	If the metal solder stencil cannot release the solder paste properly, the amount of the solder paste left on the PCB may be extremely small, causing placement errors.
	Is the solder being used not deteriorated?	Yes	No	If the solder printing operation continues for a long period of time or if deteriorated solder paste is used, it may cause printing failures and/or placement errors (e.g. due to an insufficient adhesion of the solder paste).

If the answer to an item is “No”, refer to the applicable notes provided in Note column and take necessary measures.

6. Reflow



6.1 Reflow Conditions

Figure 23 shows the Nichia recommended reflow soldering conditions provided in the applicable specification for each LED part number; use the recommended reflow conditions specified by the manufacturer of the solder paste being used if it works better for the chosen application.

Additionally, Nichia recommends using a nitrogen reflow atmosphere (O² concentration: <500ppm). If the reflow is performed with an air atmosphere, the heat and atmosphere in the reflow oven may cause the optical characteristics of the LED to degrade.

Note that reflow soldering must not be performed more than twice.

When cooling the LEDs from the peak temperature, a gradual cooling slope is recommended; do not cool the LEDs rapidly. Use the cooling rate of 1.5 to 2°C/sec. for reference. If the components mounted on the PCB are damaged and/or the solder joint strength is insufficient, the conditions should be adjusted.

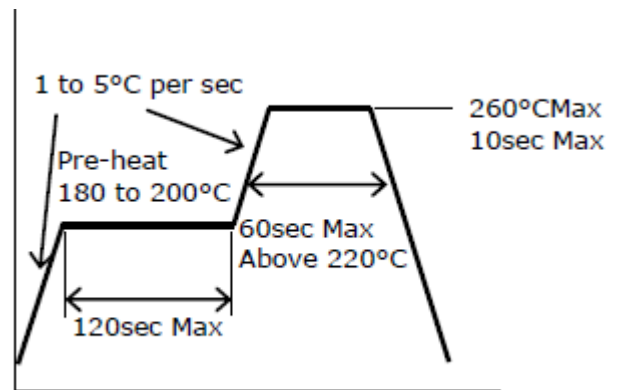

Figure 23. Reflow Soldering Condition (Lead-free Solder)

6.1.1 Details of the Reflow Soldering Profile

The reflow soldering profile has three zones: Pre-heat, Reflow, and Cooling. The following shows the role of each zone.

Pre-heat zone:

The flux contained in the solder is activated to remove the oxide film on the PCB surface.

Reflow zone:

The heat melts the solder to form an alloy.

Cooling zone:

The alloy is completed by the cooling temperatures.

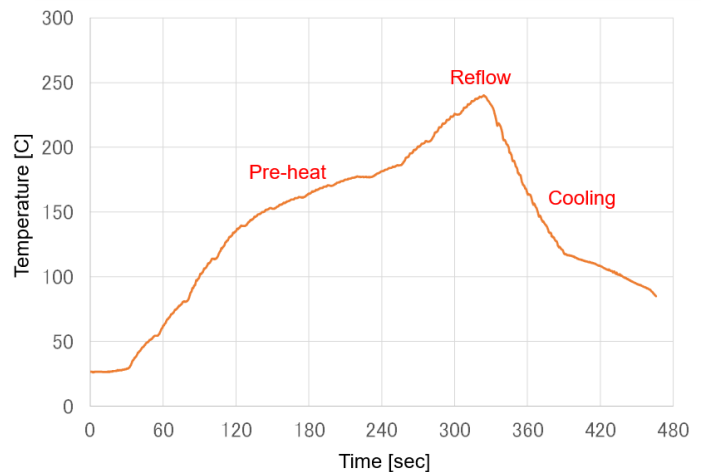

Figure 24. Example of a Reflow Profile

6.1.2 Adjusting the Reflow Soldering Profile

The following describes how to adjust the reflow profile. Refer to Figure 25.

- ① Pre-heating speed (Reference: 1 to 5°C/sec)
When it is large: Solder balls are created⁴, possibility of voids increases⁵.
- ② Pre-heat temperature
If it is high: The solder wettability declines⁶.
- ③ Pre-heat time
If it is long: The solder wettability declines.
- ④ Reflow heating speed (Reference: 1 to 5°C/sec)
If it is small: The solder wettability declines⁶.
When it is large: Solder balls are created⁴, possibility of voids increases⁵.
- ⑤ Reflow peak temperature
If it is too low: The solder wettability declines, possibility of voids increases⁵.
If it is too high: Solder balls are created⁴, the solder wettability declines.
- ⑥ Reflow time
If it is short: possibility of voids increases⁵.
- ⑦ Cooling speed (Reference: 1.5 to 2°C/sec)
If it is large: The cause of component damage due to thermal shock.
If it is small: The cause of the decrease in solder joint strength and positional deviations.
- ⑧ Cooling temperature
When the temperature at the time of PCB discharge is high: Warpage occurs within the PCB.

Note:

⁴ If solder balls are created, it will lead to a cause of a short circuit and insulation failure.

⁵ An increase in voids leads to a decrease in bonding reliability and heat dissipation.

⁶ If the solder wettability decreases, the bonding area decreases, which leads to the decrease in bonding reliability.

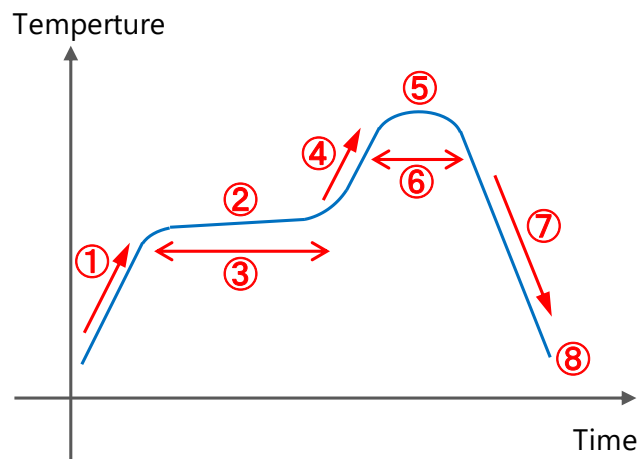

Figure 25. Description of where the reflow conditions are adjusted

6.2 Considerations for the Transfer Board

When using a transfer board for machine mounting, the PCB is placed on the transfer board (transfer jig) to move throughout the mounting process (see Figure 26); however, if the transfer board is warped, mounting failures will occur. In addition, even if there is no warpage in the transfer board in the early stages of production, warpage may occur if the same transfer board is used for the reflow process a few dozen times. It is recommended to make sure that warping does not occur by passing the material that would be used for the transfer board through the reflow process a few dozen times before using it during actual production use.

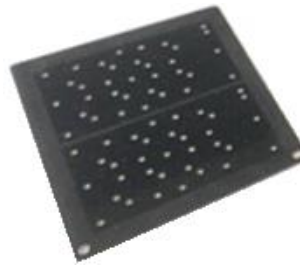

Figure 26. Transfer Board

7. Mounting Test

After completing necessary adjustments for the mounting process, conduct inspections/tests to check if there are any abnormalities in the soldering conditions or the LEDs. Table 4 shows an example of items to verify. Confirm that no issues are found in the mounting test results before carrying out the assembly operations.

Table 4. Example of Inspection/Tests to Verify the Mounting Processes

Inspection	Check Item	Probable cause(s) when there is an abnormality/failure
1 Appearance Inspection (Visual/Imaging)	Scratches Chipping Delamination	Inappropriate Nozzle Shape Excessive Nozzle Placement Pressure Burrs, Chipping, Foreign Substances on the Nozzle Tip
	LED Standing on its Side	Insufficient Amount of Solder Inappropriate Soldering Pad Pattern Inappropriate Metal Solder Stencil Aperture Pattern Misaligned Printing Position Misaligned LED Placement Position Insufficient Placement Depth for the LED Placement
	Solder Balls	Excessive Amount of Solder Paste Inappropriate Reflow Profile Misaligned Solder Printing Position
	Shape of the Solder Fillet	Inappropriate Solder Amount Inappropriate Soldering Pad Pattern Inappropriate Metal Solder Stencil Aperture Pattern Inappropriate Reflow Profile
	Floating Tilt Misalignment Insufficient Solder Coverage of the Soldering Pad	Inappropriate Solder Amount Inappropriate Soldering Pad Pattern Inappropriate Metal Solder Stencil Aperture Pattern Inappropriate Reflow Profile
2 Lighting Inspection	Emission Failure	Open Circuit due to Insufficient Amount of Solder Short Circuit due to Excessive Amount of Solder (e.g. a Solder Bridge) Disconnection due to Excessive Nozzle Placement Pressure (Identify the cause using the X-ray examination)
3 X-Ray Examination	Voids	Inappropriate Reflow Profile
	Solder Balls	Excessive Amount of Solder Inappropriate Reflow Profile
	Solder Bridges	Excessive Amount of Solder
4 Shear Strength Inspection	Shear Strength	Insufficient Amount of Solder Inappropriate Soldering Pad Pattern Inappropriate Metal Solder Stencil Aperture Pattern Inappropriate Reflow Profile

Since the mounting status changes due to slight differences in setting conditions, as well as differences in the solder paste, PCB, and mounting equipment/parts, etc.; always check and control the soldering status after mounting. By using an automatic solder visual inspection system (i.e. one that can provide an image where it is easy to judge if the image is good or if there is a defect), it is possible to improve the efficiency of work and reduce the dependence on the operator's skill compared to visual inspection (see Figure 27).

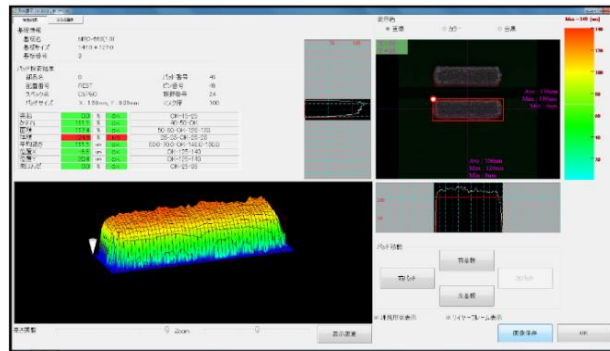

Figure 27. Example of the Inspection Using an Automatic Solder Visual Inspection System

8. Inspection



8.1 Lighting Inspection

The lighting inspection is performed either visually or using an automatic imaging inspection system to check if all the LEDs emit light without issues.

8.1.1 Lighting Inspection Considerations

In order to prevent the LEDs from being damaged during the lighting inspection, operate the LEDs at a constant current and ensure that the voltage being applied is appropriate for the chosen circuit of the PCB and that the current being applied is small enough (e.g. 1mA per LED).

Additionally, ensure that a hot-wire connection⁷ of the probes, etc. is not done during the lighting inspection; if the chosen voltage and current are not appropriate, a large current exceeding the absolute maximum rating current⁸ may temporarily flow through the LEDs due to the inrush current (see Figure 28) causing damage to the LEDs (see Figure 29).

Note:

⁷ A hot-wire connection means a test voltage is applied to the PCB with probes, etc. while the power is on.

⁸ Absolute maximum ratings of the LEDs are the maximum values that must not be exceeded even for a short period of time. For the absolute maximum rating values for each LED, refer to the applicable specification.

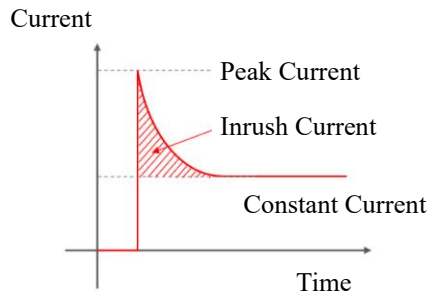

Figure 28. Example of an inrush current waveform



Damaged Electrodes of the LED chip due to an Inrush Current.

Figure 29. Example of an LED Damaged due to an Inrush Current

8.2 Electrical Characteristics Inspection

An electrical characteristics inspection should be performed to confirm that the designed value of the current flows through the LED when it is operated and that the voltage value is appropriate for the current flowing through the LED.

8.3 Appearance Inspection

An appearance inspection should be performed visually or using an automatic imaging inspection system to check if there are any abnormalities in appearance (e.g. misalignment/floating of the LED, solder balls, damage to the LED, etc.).

8.4 X-Ray Examination

An X-ray examination should be performed to check if the solder wettability is sufficient and/or if there are any solder voids, solder balls, etc.

9. Precautions for Assembled PCBs

When handling the assembled PCBs, ensure that the following precautions are followed.

- Do not stack assembled PCBs together. Otherwise, it may cause damage to the emitting area and/or the resin (e.g. cut, scratch, chip, crack, etc.) and have an effect on the optical characteristics and/or the reliability.
- If the LEDs are soldered to a PCB and the PCB assembly is bent (e.g. PCB depaneling process), it may cause the LED package to break. To separate a PCB populated with the LEDs, use a specially designed tool. Do not break the PCB by hand; this may cause excessive stress to be applied to the LEDs.

10. Summary

The occurrence of mounting failures for the LED mounting process may vary depending on various factors including the work environments, equipment, conditions of the materials being used, etc. Ensure that there are no issues with the mounting operations by performing a mounting test, etc. before starting the operations. In cases where the mounting operations are not successful with Nichia's recommended conditions, it is best for customers to understand the trends for the processes chosen for the applications, accumulate actual test data, and be able to respond daily to any necessary changes/adjustments to the processes.

Disclaimer

This application note is a controlled document of Nichia Corporation (Nichia) published to provide technical information/data for reference purposes only. By using this application note, the user agrees to the following:

- This application note has been prepared solely for reference on the subject matters incorporated within it and Nichia makes no guarantee that customers will see the same results for their chosen application.
- The information/data contained herein are only typical examples of performances and/or applications for the product. Nichia does not provide any guarantees or grant any license under or immunity from any intellectual property rights or other rights held by Nichia or third parties.
- Nichia makes no representation or warranty, express or implied, as to the accuracy, completeness or usefulness of any information contained herein. In addition, Nichia shall not be liable for any damages or losses arising out of exploiting, using, or downloading or otherwise this document, or any other acts associated with this document.
- The content of this application note may be changed without any prior or subsequent notice.
- Copyrights and all other rights regarding the content of this document are reserved by Nichia or the right holders who have permitted Nichia to use the content. Without prior written consent of Nichia, republication, reproduction, and/or redistribution of the content of this document in any form or by any means, whether in whole or in part, including modifications or derivative works hereof, is strictly prohibited.